

# BARRIER WASHER EXTRACTORS

## POWER, CONTROL AND TOTAL DESINFECTION

### FEATURES

### ASM-16-22 TOUCH

- High spin soft mounted washer extractor, no need of anchorage, 2 opposed doors.
- Capacity 16 and 22 kg.
- Extraction speed 1.000 Rpm.
- G force 350.
- Body, drum and vat in stainless steel.
- Horizontally suspended drum by means of two axles which increase robustness, 1 compartment.
- Soap dispenser with 4 compartments.
- 8 signals for liquid dosing.
- Three water inlets standard in all range.
- Out of balance detection by means of the inverter.
- New TOUCH microprocessor with a lot of devices for a greater flexibility. 26 preset programs, unlimited creation of new programs.
- WET CLEANING system integrated (standard).
- OPTIMAL LOAD system integrated: manual indication of load.
- Traceability - storage of data.
- Electric or steam heating.
- Standard double display.



### OPTIONS

- 2nd drain valve.
- Central position drain valve.
- Detergent bath sampling.
- Weighing sensor system on feet.
- Electric brake.
- Relay card to increase up to 14 signals for liquid dosing.
- Dual heating electric+steam.
- Plinth up to height 850mm door bottom.
- Stainless steel wall frame.



TECHNICAL DATA	UNIT.	ASM-16 TOUCH	ASM-22 TOUCH		
<b>DRUM</b>					
Capacity 1:9 / 1:10	Kg	18 / 16	25 / 22		
Volume	l	158	220		
Diameter	mm	633	633		
Depth	mm	500	700		
Number of compartments	Nº.	1	1		
<b>GENERAL DETAILS</b>					
Washing speed / Spining speed	r.p.m.	45 / 1.000	45 / 1.000		
G Factor	-	350	350		
Maximum force transmitted	KN	5,5 ±1,12	6,25 ±1,54		
Frequency-dynamic force	Hz	16,7	16,7		
Sound level	dB	< 70	< 70		
Double drain	-	Opt	Opt		
Weighing System	-	Opt	Opt		
<b>DOOR</b>					
Height base door	mm	670	670		
Drum opening dimensions	mm	400 x 315	400 x 315		
Vat opening dimensions	mm	455 x 415	455 x 415		
<b>POWER</b>					
Motor	kW	2,2	2,2		
Electric heating	kW	12	18		
Max. power (Electric model)	kW	14,2	20,2		
Max. power (Hot water model)	kW	2,2	2,2		
Max. power (Steam model)	kW	2,2	2,2		
<b>CONNECTIONS</b>		<b>ELECTRIC</b>	<b>STEAM / HOT WATER</b>	<b>ELECTRIC</b>	<b>STEAM / HOT WATER</b>
Tension 230V- I + N + T	Nº x mm2 / A	-	2 x 1,5 / 6A	-	3 x 1,5 / 6A
Tension 230V- III + T	Nº x mm2 / A	3 x 10 / 40A	-	3 x 10 / 50A	-
Tension 400V- III + N + T	Nº x mm2 / A	4 x 6 / 25A	-	4 x 6 / 32A	-
Steam inlet (Steam mod.)	inch		3/4"		3/4"
Maximum steam consumption (Steam mod.)	Kg/h		9		12
Water inlet	inch		3/4"		3/4"
Water main pressure	Kgs/cm <sup>2</sup>		3-5		3-5
Maximum water consumption*	Lit/h		144*		198*
Drain	mm/inch		3"		3"
Drainage capacity	Lit/min		200		200
<b>DIMENSIONS / PACKING DIMENSIONS</b>					
Width / Width	mm		984 / 1.072		1.184 / 1.262
Depth / Depth	mm		914 / 1.102		914 / 1.102
Height / Height	mm		1398 / 1.530		1.398 / 1.530
Net weight / Gross weight	kg		438 / 459		471 / 494
Volume	m <sup>3</sup>		1,65		1,94

\* N°2 Program, 100% load

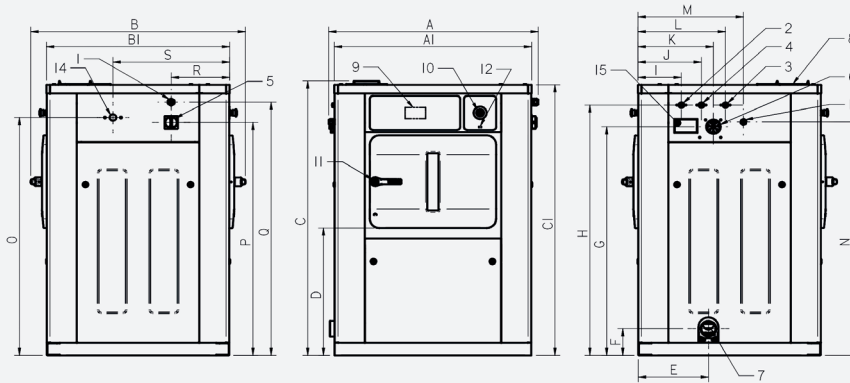

- 01. Electrical connection
- 02. Hot water
- 03. Cold water
- 04. Soft water
- 05. Main switch
- 06. Liquid soap inlet
- 07. Drain
- 08. Soap box
- 09. Control panel
- 10. Emergency stop button
- 11. Door opening
- 12. USB port
- 13. Pump connection for soap box
- 14. Steam inlet
- 15. Vent

	A	B	C	A1	B1	C1	D	E	F	G	H	I	J	K	L	M	N	O	P	Q	R	S
ASM-16	1.056	1.071	1.417	984	914	1.398	658	350	138	1.180	1.292	216	316	377	436	527	1.205	1.228	1.203	1.308	292	582
ASM-22	1.245	1.071	1.417	1.184	914	1.398	658	350	138	1.180	1.292	216	316	377	436	527	1.205	1.228	1.203	1.308	292	582