



BARRIER WASHER EXTRACTORS

POWER, CONTROL AND TOTAL DESINFECTION

FEATURES

- High spin soft mounted washer extractor, no need of anchorage, 2 opposed doors.
- Capacity 33 kg.
- Extraction speed 990 Rpm.
- G force 400.
- Body, drum and vat in stainless steel.
- Horizontally suspended drum by means of two axles which increase robustness, 1 compartment.
- Soap dispenser with 4 compartments.
- 8 signals for liquid dosing.
- Three water inlets standard in all range.
- Out of balance detection by means of the inverter.
- New TOUCH microprocessor with a lot of devices for a greater flexibility. 26 preset programs, unlimited creation of new programs.
- WET CLEANING system integrated (standard).
- OPTIMAL LOAD system integrated: manual indication of load.
- Traceability - storage of data.
- Electric or steam heating.
- Standard double display.

ASM-35 TOUCH



OPTIONS

- 2nd drain valve.
- Central position drain valve.
- Detergent bath sampling.
- Weighing sensor system on feet.
- Electric brake.
- Relay card to increase up to 14 signals for liquid dosing.
- Dual heating electric+steam.
- Plinth up to height 850mm door bottom.
- Stainless steel wall frame.

Touch
Technology

Stainless
Steel
Standard

Hot & Cold
MIX

Imbalance
Inverter

WET
Cleaning

Optimal
Loading

Easy
Maint.

Soft
O-Recycle

Auto
Weight

TECHNICAL DATA	UNIT.	ASM-35 TOUCH	
DRUM			
Capacity 1:9 / 1:10	Kg	37 / 33	
Volume	l	330	
Diameter	mm	800	
Depth	mm	654	
Number of compartments	Nº.	1	
GENERAL DETAILS			
Washing speed / Spining speed	r.p.m.	45 / 1.000	
G Factor	-	400	
Maximum force transmitted	KN	10,4 ±2,9	
Frequency-dynamic force	Hz	16,7	
Sound level	dB	< 70	
Double drain	-	Opt	
Weighing System	-	Opt	
DOOR			
Height base door	mm	776	
Drum opening dimensions	mm	450 x 320	
Vat opening dimensions	mm	510 x 460	
POWER			
Motor	kW	4	
Electric heating	kW	27	
Max. power (Electric model)	kW	31	
Max. power (Hot water model)	kW	4	
Max. power (Steam model)	kW	4	
CONNECTIONS			
		ELECTRIC	STEAM / HOT WATER
Tension 230V- I + N + T	Nº x mm2 / A	-	-
Tension 230V- III + T	Nº x mm2 / A	3 x 16 / 100A	3 x 2,5 / 16A
Tension 400V- III + N + T	Nº x mm2 / A	4 x 10 / 50A	4 x 2,5 / 10A
Steam inlet (Steam mod.)	inch	3/4"	
Maximum steam consumption (Steam mod.)	Kg/h	18	
Water inlet	inch	3/4"	
Water main pressure	Kgs/cm ²	3-5	
Maximum water consumption*	Lit/h	260*	
Drain	mm/inch	3"	
Drainage capacity	Lit/min	200	
DIMENSIONS / PACKING DIMENSIONS			
Width / Width	mm	1.280 / 1.452	
Depth / Depth	mm	1.060 / 1.222	
Height / Height	mm	1.580 / 1.694	
Net weight / Gross weight	kg	748 / 780	
Volume	m ³	3,01	

* Nº2 Program, 100% load

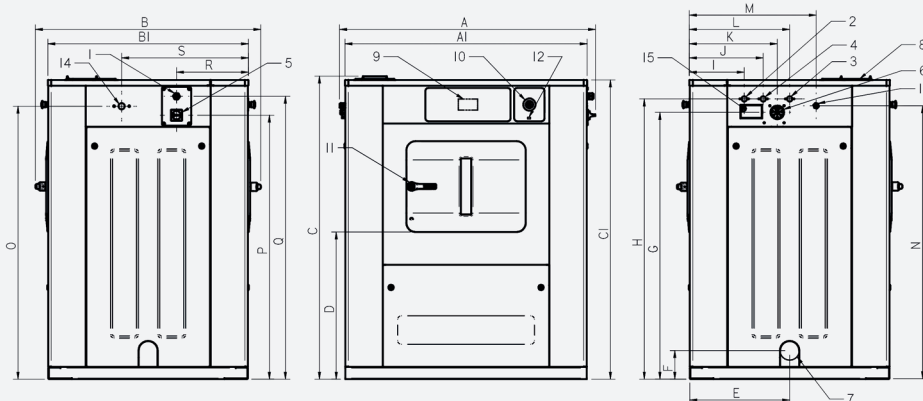

01. Electrical connection
02. Hot water
03. Cold water
04. Soft water
05. Main switch
06. Liquid soap inlet
07. Drain
08. Soap box
09. Control panel
10. Emergency stop button
11. Door opening
12. USB port
13. Pump connection for soap box
14. Steam inlet
15. Vent

	A	B	C	A1	B1	C1	D	E	F	G	H	I	J	K	L	M	N	O	P	Q	R	S
ASM-35	1.352	1.191	1.601	1.280	1.060	1.580	778	528	152	1.409	1.480	290	390	465	530	670	1.441	1.441	1.394	1.494	380	670