

BARRIER WASHER EXTRACTORS

POWER, CONTROL AND TOTAL DESINFECTION

FEATURES

- High spin soft mounted washer extractor, no need of anchorage, 2 opposed doors.
- Capacity 67 kg.
- Extraction speed 945 Rpm.
- G force 350.
- Body, drum and vat in stainless steel.
- Horizontally suspended drum by means of two axles which increase robustness, 2 compartments.
- Soap dispenser with 4 compartments.
- 8 signals for liquid dosing.
- Three water inlets standard in all range.
- Out of balance detection by means of the inverter.
- New TOUCH microprocessor with a lot of devices for a greater flexibility. 26 preset programs, unlimited creation of new programs.
- WET CLEANING system integrated (standard).
- OPTIMAL LOAD system integrated: manual indication of load.
- Traceability - storage of data.
- Electric or steam heating.
- Standard double display.

ASM-66 TOUCH



OPTIONS

- 2nd drain valve.
- Central position drain valve.
- Detergent bath sampling.
- Weighing sensor system on feet.
- Electric brake.
- Relay card to increase up to 14 signals for liquid dosing.
- Dual heating electric+steam.
- Plinth up to height 850mm door bottom.
- Stainless steel wall frame.

Touch
Technology

Stainless
Steel
Standard

Hot & Cold
MIX

Imbalance
Inverter

WET
Cleaning

Optimal
Loading

Easy
Maint.

Soft
O-Recycle

Auto
Weight

TECHNICAL DATA	UNIT.	ASM-66 TOUCH	
DRUM			
Capacity 1:9 / 1:10	Kg	74 / 67	
Volume	l	667	
Diameter	mm	800	
Depth	mm	1.327	
Number of compartments	Nº.	2	
GENERAL DETAILS			
Washing speed / Spining speed	r.p.m.	45 / 900	
G Factor	-	350	
Maximum force transmitted	KN	17,13 ±4,8	
Frequency-dynamic force	Hz	15	
Sound level	dB	< 70	
Double drain	-	Opt	
Weighing System	-	Opt	
DOOR			
Height base door	mm	798	
Drum opening dimensions	mm	450 x 320	
Vat opening dimensions	mm	510 x 460 (x2)	
POWER			
Motor	kW	7,5	
Electric heating	kW	45	
Max. power (Electric model)	kW	52,5	
Max. power (Hot water model)	kW	7,5	
Max. power (Steam model)	kW	7,5	
CONNECTIONS			
		ELECTRIC	STEAM / HOT WATER
Tension 230V- I + N + T	Nº x mm2 / A	-	-
Tension 230V- III + T	Nº x mm2 / A	3 x 35 / 160A	3 x 2,5 / 16A
Tension 400V- III + N + T	Nº x mm2 / A	4 x 16 / 80A	4 x 2,5 / 10A
Steam inlet (Steam mod.)	inch		3/4"
Maximum steam consumption (Steam mod.)	Kg/h		34,2
Water inlet	inch		1"
Water main pressure	Kgs/cm ²		3-5
Maximum water consumption*	Lit/h		730*
Drain	mm/inch		3"
Drainage capacity	Lit/min		200
DIMENSIONS / PACKING DIMENSIONS			
Width / Width	mm	1.955 / 2.102	
Depth / Depth	mm	1.062 / 1.222	
Height / Height	mm	1.660 / 1.694	
Net weight / Gross weight	kg	1.233 / 1.275	
Volume	m ³	4,35	

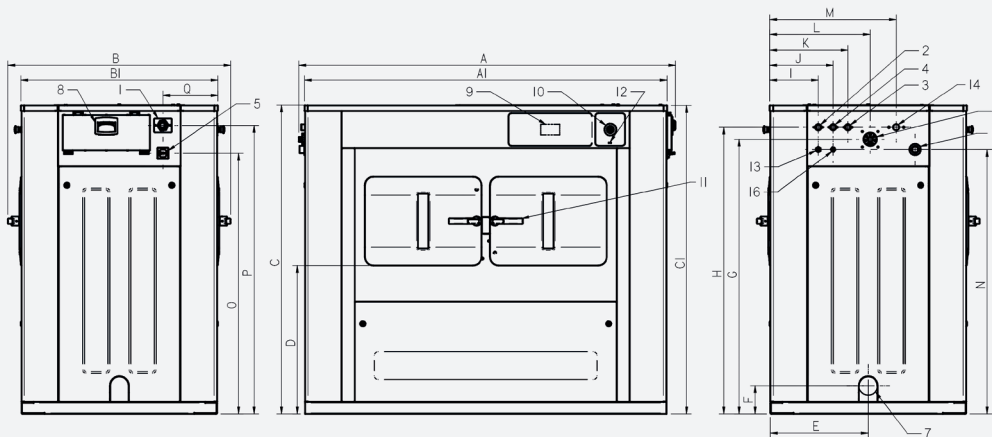

* Nº2 Program, 100% load

- 01. Electrical connection
- 02. Hot water
- 03. Cold water
- 04. Soft water
- 05. Main switch
- 06. Liquid soap inlet
- 07. Drain
- 08. Soap box
- 09. Control panel
- 10. Emergency stop button
- 11. Door opening
- 12. USB port
- 13. Pump connection for soap box
- 14. Steam inlet
- 15. Vent
- 16. Water for soap box

	A	B	C	A1	B1	C1	D	E	F	G	H	I	J	K	L	M	N	O	P	Q	R	S
ASM-66	2.032	1.201	1.662	1.955	1.062	1.660	798	528	152	148	1.543	262	342	422	542	682	1.423	1.403	1.553	296	-	-