



# CLEANROOM BARRIER WASHER EXTRACTORS

NEW TOUCH CONTROL MICROPROCESSOR

## FEATURES

- High spin soft mounted washer extractor, 2 opposed doors to avoid cross contamination.
- Panels, drum and vat in stainless steel AISI 304.
- Horizontally suspended drum by means of two axles which increase robustness, 1 compartment.
- Capacity 16 and 22 kg.
- Front loading of dirty linen and back unloading of clean linen.
- 8 signals for liquid dosing.
- Two water inlets standard, with plastic valves.
- Out of balance detection by means of the inverter.
- New TOUCH CONTROL microprocessor with a lot of devices for a greater flexibility.
- 26 preset programs, unlimited creation of new programs.
- Wet Cleaning system integrated (standard).
- Optimal load system integrated: manual indication of load.
- Standard double display.
- Electric or steam heating.
- Extraction speed 1000 RPM.
- G force 350.
- Side panel divided into two, for easy maintenance of the drain.

## ASM-16-22 TOUCH CLEANROOM



## OPTIONS

- Drum and vat in stainless steel AISI 316 L.
- Drum and vat in electropolished stainless steel.
- Titration valve.
- Pack stainless steel connections (pipes, water and air intakes) + Hepa air filter.
- Third water intake.
- Pack stainless steel: painted parts are replaced by stainless steel parts.
- Central position drain valve.
- Drum electric brake.
- Relay card to increase up to 14 signals for liquid dosing.
- Plinth up to height 850 mm from door bottom.
- Stainless steel wall frame with rubber.



TECHNICAL DATA	UNIT.	ASM-16 TOUCH CLEANROOM	ASM-22 TOUCH CLEANROOM		
<b>DRUM</b>					
Capacity 1:9 / 1:10	Kg	18 / 16	25 / 22		
Volume	l	158	220		
Diameter	mm	633	633		
Depth	mm	500	700		
Number of compartments	Nº.	1	1		
<b>GENERAL DETAILS</b>					
Washing speed / Spining speed	r.p.m.	45 / 1.000	45 / 1.000		
G Factor	-	350	350		
Maximum force transmitted	KN	5,5 ±1,12	6,25 ±1,54		
Frequency-dynamic force	Hz	16,7	16,7		
Sound level	dB	< 70	< 70		
Double drain	-	Opt	Opt		
Weighing System	-	Opt	Opt		
<b>DOOR</b>					
Height base door	mm	670	670		
Drum opening dimensions	mm	400 x 315	400 x 315		
Vat opening dimensions	mm	455 x 415	455 x 415		
<b>POWER</b>					
Motor	kW	2,2	2,2		
Electric heating	kW	12	18		
Max. power (Electric model)	kW	14,2	20,2		
Max. power (Hot water model)	kW	2,2	2,2		
Max. power (Steam model)	kW	2,2	2,2		
<b>CONNECTIONS</b>		<b>ELECTRIC</b>	<b>STEAM / HOT WATER</b>	<b>ELECTRIC</b>	<b>STEAM / HOT WATER</b>
Tension 230V- I + N + T	Nº x mm2 / A	-	2 x 1,5 / 6A	-	3 x 1,5 / 6A
Tension 230V- III + T	Nº x mm2 / A	3 x 10 / 40A	-	3 x 10 / 50A	-
Tension 400V- III + N + T	Nº x mm2 / A	4 x 6 / 25A	-	4 x 6 / 32A	-
Steam inlet (Steam mod.)	inch		3/4"		3/4"
Maximum steam consumption (Steam mod.)	Kg/h		9		12
Water inlet	inch		3/4"		3/4"
Water main pressure	Kgs/cm <sup>2</sup>		3-5		3-5
Maximum water consumption*	Lit/h		144*		198*
Drain	mm/inch		3"		3"
Drainage capacity	Lit/min		200		200
<b>DIMENSIONS / PACKING DIMENSIONS</b>					
Width / Width	mm		984 / 1.072		1.184 / 1.262
Depth / Depth	mm		914 / 1.102		914 / 1.102
Height / Height	mm		1398 / 1.530		1.398 / 1.530
Net weight / Gross weight	kg		438 / 459		471 / 494
Volume	m <sup>3</sup>		1,65		1,94

\* N°2 Program, 100% load

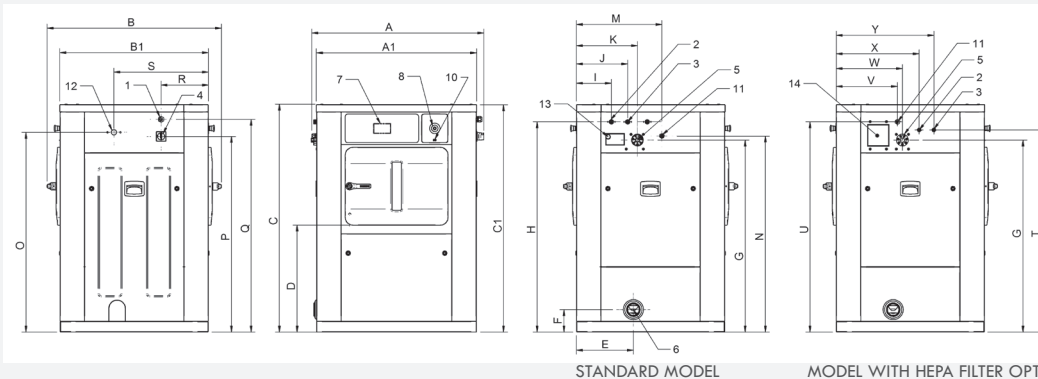

01. Electrical connection
02. Cold water
03. Soft water
04. Main switch
05. Liquid soap inlet
06. Drain
07. Control panel
08. Emergency stop button
09. Door opening
10. USB port
11. Pump connection for soap box
12. Steam inlet
13. Vent
14. HEPA filter

	A	B	C	A1	B1	C1	D	E	F	G	H	I	J	K	L	M	N	O	P	Q	R	S	T	U	V	W	X	Y
ASM-16	1056	1071	1401	984	914	1398	657	350	138	1180	1292	216	316	377	436	527	1205	1228	1203	1308	292	582	1242	1292	377	407	510	600
ASM-22	1256	1071	1401	1184	914	1398	657	350	138	1180	1292	216	316	377	436	527	1205	1228	1203	1308	292	582	1242	1292	377	407	510	600