



# CLEANROOM BARRIER WASHER EXTRACTORS

NEW TOUCH CONTROL MICROPROCESSOR

## ASM-35 TOUCH CLEANROOM

### FEATURES

- High spin soft mounted washer extractor, 2 opposed doors to avoid cross contamination.
- Panels, drum and vat in stainless steel AISI 304.
- Horizontally suspended drum by means of two axles which increase robustness, 1 compartment.
- Capacity 35 kg.
- Front loading of dirty linen and back unloading of clean linen.
- 8 signals for liquid dosing.
- Two water inlets standard, with plastic valves.
- Out of balance detection by means of the inverter.
- New TOUCH CONTROL microprocessor with a lot of devices for a greater flexibility.
- 26 preset programs, unlimited creation of new programs.
- Wet Cleaning system integrated (standard).
- Optimal load system integrated: manual indication of load.
- Standard double display.
- Electric or steam heating.
- Extraction speed 1000 RPM.
- G force 400.
- Side panel divided into two, for easy maintenance of the drain.



### OPTIONS

- Drum and vat in stainless steel AISI 316 L.
- Drum and vat in electropolished stainless steel.
- Titration valve.
- Pack stainless steel connections (pipes, water and air intakes) + HEPA air filter.
- Third water intake.
- Pack stainless steel: painted parts are replaced by stainless steel parts.
- Central position drain valve.
- Drum electric brake.
- Relay card to increase up to 14 signals for liquid dosing.
- Plinth up to height 850 mm from door bottom.
- Stainless steel wall frame with rubber.



TECHNICAL DATA		UNIT.	ASM-35 TOUCH CLEANROOM
<b>DRUM</b>			
Capacity 1:9 / 1:10		Kg	37 / 33
Volume		l	330
Diameter		mm	800
Depth		mm	654
Number of compartments		Nº.	1
<b>GENERAL DETAILS</b>			
Washing speed / Spining speed		r.p.m.	45 / 1.000
G Factor		-	400
Maximum force transmitted		KN	10,4 ±2,9
Frequency-dynamic force		Hz	16,7
Sound level		dB	< 70
Double drain		-	Opt
Weighing System		-	Opt
<b>DOOR</b>			
Height base door		mm	776
Drum opening dimensions		mm	450 x 320
Vat opening dimensions		mm	510 x 460
<b>POWER</b>			
Motor		kW	4
Electric heating		kW	27
Max. power (Electric model)		kW	31
Max. power (Hot water model)		kW	4
Max. power (Steam model)		kW	4
<b>CONNECTIONS</b>			
Tension 230V- I + N + T	Nº x mm2 / A	ELECTRIC	STEAM / HOT WATER
Tension 230V- III + T	Nº x mm2 / A	-	-
Tension 400V- III + N + T	Nº x mm2 / A	3 x 16 / 100A	3 x 2,5 / 16A
Steam inlet (Steam mod.)	inch	4 x 10 / 50A	4 x 2,5 / 10A
Maximum steam consumption (Steam mod.)	Kg/h		3/4"
Water inlet	inch		18
Water main pressure	Kgs/cm <sup>2</sup>		3/4"
Maximum water consumption*	Lit/h		3-5
Drain	mm/inch		260*
Drainage capacity	Lit/min		3"
<b>DIMENSIONS / PACKING DIMENSIONS</b>			
Width / Width	mm		1.280 / 1.452
Depth / Depth	mm		1.060 / 1.222
Height / Height	mm		1.580 / 1.694
Net weight / Gross weight	kg		748 / 780
Volume	m <sup>3</sup>		3,01

\* Nº2 Program, 100% load

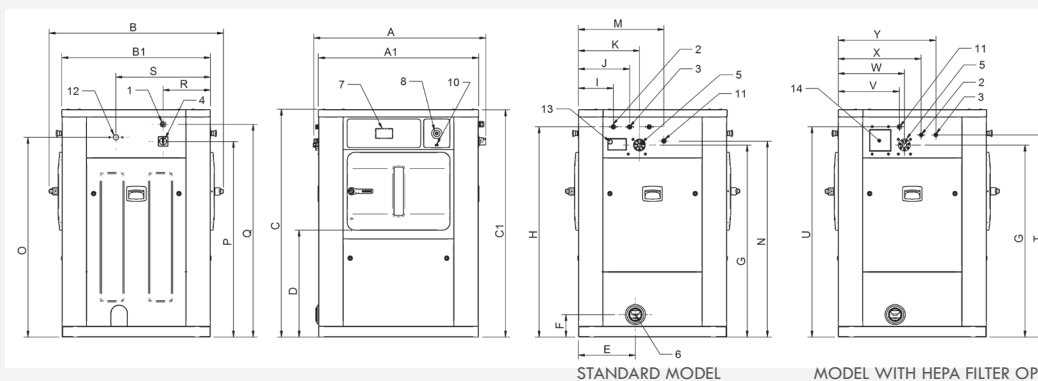

01. Electrical connection
02. Cold water
03. Soft water
04. Main switch
05. Liquid soap inlet
06. Drain
07. Control panel
08. Emergency stop button
09. Door opening
10. USB port
11. Pump connection for soap box
12. Steam inlet
13. Vent
14. HEPA filter

	A	B	C	A1	B1	C1	D	E	F	G	H	I	J	K	L	M	N	O	P	Q	R	S	T	U	V	W	X
ASM-35	1352	1191	1584	1280	1060	1580	778	528	138	1409	1470	600	700	465	530	670	1400	1441	1394	1494	380	670	1445	1510	435	590	690